



Emergency Vehicle Cable and Hose Management

- Run cables or air hoses quickly...no tangling.
- Quickly respool cables and hoses...automatically.



**Spring powered, automatic rewind reels
from the leader in cable and hose management.**

When seconds count, rely on Gleason Cable-Master Reels

When the call comes in, emergency vehicles must be ready to roll, get to the scene, and spring into action. There is no time for engine warm-up or air brake charging.

There is no time to uncoil tangled extension cords to provide auxiliary power.

Mounted overhead at the station house or dockside at a fire boat mooring keeping diesel engines warm and batteries charged, or on the vehicle itself for quick cable deployment at the scene, Gleason reels are designed, tested and proven to withstand the rigors associated with fire and rescue operations.



Cable-Master Reels mounted overhead at station provide "off-duty" power to vehicles. Also shown, a Hose-Master to keep air brakes charged. Both can be equipped with sockets which automatically disconnect when engine starts.



Pull out as much cable as needed to power remote lights. Spring rewind without hand cranking or coiling. Reels may be hard wired to generator or equipped with "pig tail" for greater versatility and portability.

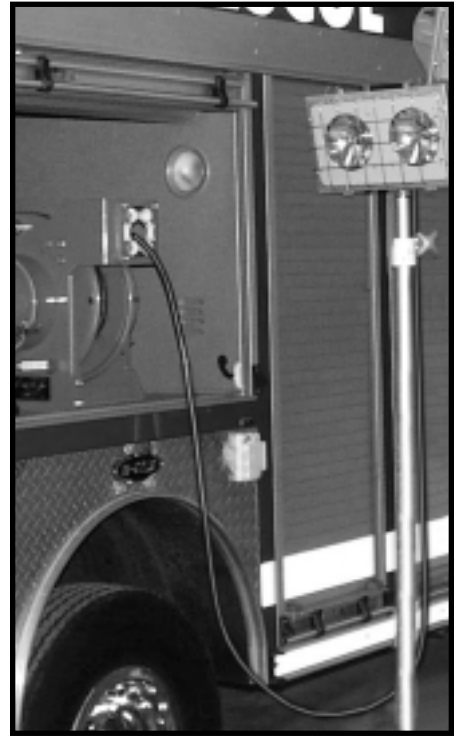

Truck mounted reels can provide up to 90' of cable. See chart (right) for reel sizes and capacities. Models with greater capacities to handle longer or larger cables, including "wide body" reels, also available. Please consult factory for details.



Cable-Master used with heat sensing camera monitor. Set-up monitor in location which allows easy access and provides best lighting.

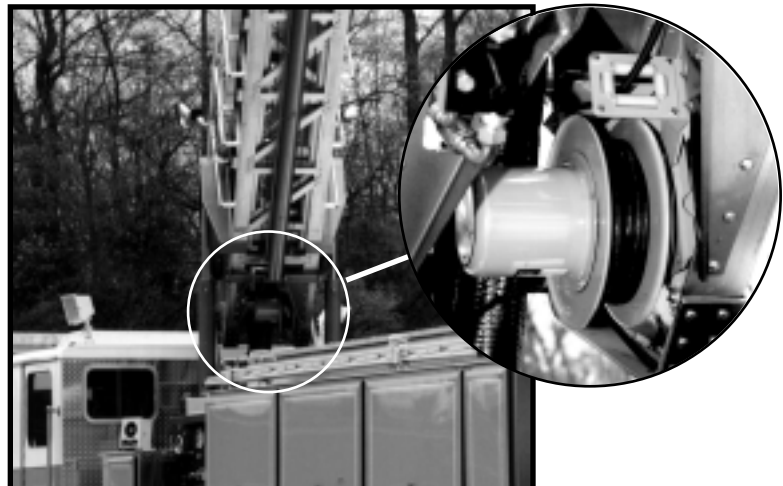

Cable-Master supplies power to lights at top of aerial ladder. Reel automatically extends and retracts cable.

CABLE REELS FEATURE:

- All-Welded Solid Steel Construction
- Slip Rings in NEMA 4 Enclosure
- Generously Sized Junction Box
- Heavy Duty Mounting Base
- Safetychange® Spring Motor
- Weatherproof Gasket on Spring Motor
- Positive Ratchet Lock with Disengage
- Multi-position Cable Guide (Field Adjustable)
- Orange Polyester Baked-On Finish
- Cable Included (Does NOT include connector)
- Field Adjustable Cable Stop Included



Gleason Cable-Master Reels

14", 16", and 19" Reels
20'–90' Cable Included

(Shown above with duplex box, optional extra)

CABLE DATA				REEL CATALOG NUMBER	FLANGE DIA. in. (mm)	WEIGHT COMPLETE lbs. (kg)
TYPE SO CORD						
RATING @ 600V	AWG	NO. COND.	LENGTH* ft. (m)			
10 Amp	16	3	20 (6.0)	G14-A03-A0204	14 (356)	43 (19.4)
			30 (9.0)	G14-A03-B0302		46 (20.3)
			40 (12.0)	G14-A03-C0402		51 (23.0)
			50 (15.0)	G16-A03-D0502	16 (406)	84 (37.8)
			60 (18.0)	G16-A03-J0605		82 (36.9)
			70 (21.0)	G19-A03-D0701		97 (43.7)
			80 (24.0)	G19-A03-J0803		95 (42.8)
90 (27.0)	G19-A03-J0903	96 (43.2)				
8 Amp	16	4	20 (6.0)	G14-A04-A0205	14 (356)	44 (19.8)
			30 (9.0)	G14-A04-B0303		47 (21.2)
			40 (12.0)	G14-A04-C0402		53 (23.9)
			50 (15.0)	G16-A04-D0502	16 (406)	85 (38.3)
			60 (18.0)	G16-A04-J0605		84 (37.8)
			70 (21.0)	G19-A04-D0701		100 (45.0)
			80 (24.0)	G19-A04-J0804		98 (44.1)
90 (27.0)	G19-A04-J0904	99 (44.6)				
15 Amp	14	3	20 (6.0)	G14-B03-A0205	14 (356)	45 (20.3)
			30 (9.0)	G14-B03-B0303		48 (21.6)
			40 (12.0)	G14-B03-C0402		56 (25.2)
			50 (13.5)	G14-B03-C0502	16 (406)	57 (25.7)
			60 (18.0)	G16-B03-J0605		87 (39.2)
			70 (21.0)	G19-B03-J0705		100 (45.0)
			80 (24.0)	G19-B03-K0802		91 (40.1)
12 Amp	14	4	20 (6.0)	G14-B04-A0205	14 (356)	46 (20.7)
			30 (9.0)	G14-B04-B0303		49 (22.1)
			40 (12.0)	G14-B04-C0403		57 (25.7)
			50 (15.0)	G14-B04-C0503	16 (406)	59 (26.6)
			60 (18.0)	G16-B04-J0607		89 (40.1)
			70 (21.0)	G19-B04-G0703		90 (40.5)
			80 (24.0)	G19-B04-K0803		95 (42.8)
20 Amp	12	3	20 (6.0)	G14-C03-A0205	14 (356)	46 (20.7)
			30 (9.0)	G14-C03-B0303		50 (22.5)
			40 (12.0)	G14-C03-C0406		58 (26.1)
			50 (15.0)	G16-C03-G0504	16 (406)	78 (35.1)
			60 (18.0)	G19-C03-K0603		92 (41.4)
			70 (21.0)	G19-C03-G0703		91 (41.0)
			80 (24.0)	G19-C03-K0803		97 (43.7)
16 Amp	12	4	20 (6.0)	G14-C04-A0207	14 (356)	47 (21.2)
			30 (9.0)	G14-C04-B0303		52 (23.4)
			40 (12.0)	G14-C04-B0403		54 (24.3)
			50 (15.0)	G16-C04-G0504	16 (406)	80 (36.0)
			60 (18.0)	G16-C04-K0604		93 (41.9)
			70 (21.0)	G19-C04-G0705		94 (42.3)
			80 (24.0)	G19-C04-D0802		112 (50.4)

G14 & G16 models are UL and CSA listed.

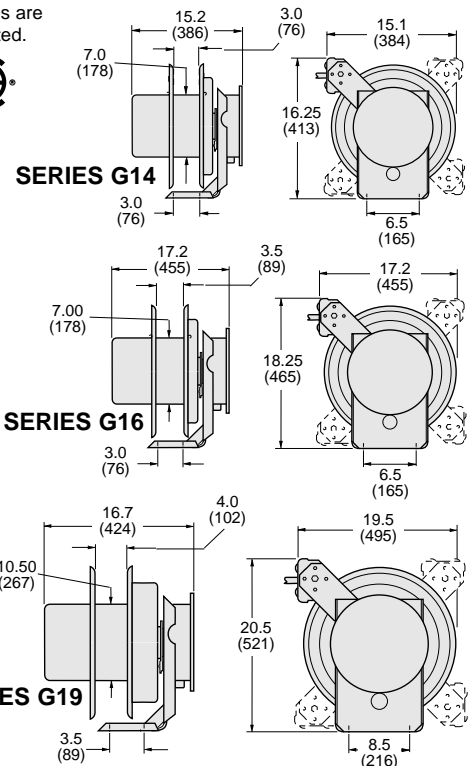

Other models available. Please consult factory if reels with longer cable, larger cable or more conductors are required.

ACCESSORIES

340° PIVOT BASE (Optional)

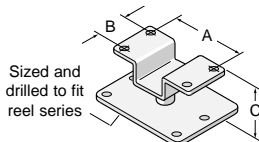

Aligns reel to the direction of cable run. Steel construction with orange polyester baked on finish. May be mounted with reel upright or hanging. Available for all models.

REEL DIA.	PIVOT BASE	HOLE DIA. in. mm	DIM. "A" in. mm	DIM. "B" in. mm	DIM. "C" in. mm
14"	#PB14	0.44 (11.2)	3.0 (76)	3.0 (76)	2.0 (51)
16"	#PB16	0.53 (13.5)	6.0 (152)	6.0 (152)	3.0 (76)
19"	#PB19	0.53 (13.5)	6.5 (165)	6.5 (165)	3.0 (76)

DUPLEX RECEPTACLE BOX



Model DR-120

Duplex Receptacle Only.
Does not include reel.

Rubber Box, Two Outlets
NEMA #5-15R Receptacles
Available separately. Must be installed by customer.

NOTE:

Because cable end connector requirements vary greatly, all reels are shipped with cable installed but with no connector. Suggested connectors range from standard or twist-lock single receptacles to duplex boxes (like that shown at left) to sophisticated automatic disconnect plugs. **All end connectors must be customer installed.**

Hose-Master Air Hose Reels

HOSE REELS FEATURE:

- 1/4", 3/8", or 1/2" (6, 9, 13mm) hose
- All welded solid steel construction
- Fully automatic; Machine mountable
- Heavy duty mounting bracket
- Safetychange® spring motor
- Weatherproof gasket on spring motor
- Positive ratchet lock with disengage
- Multi-position adjustable hose guide
- Orange polyester baked-on finish
- Mount reel with base up, down or on vertical support.
- Optional 340° pivot base
- Optional adjustable hose stop
- Also available without hose



HOSE DATA				REEL WITH HOSE		REEL LESS HOSE		REEL SIZE	340° BASE (OPT)	HOSE STOP (OPT)
INSIDE DIA. in. (mm)	INPUT & OUTPUT FITTINGS	MAX LENGTH ft. (m)	MAX PRES. psi (N/mm ²)	MODEL NO.	NET WEIGHT lbs. (kg)	MODEL NO.	NET WEIGHT lbs. (kg)			
1/4 (6)	0.25 NPTF	25 (7.5)	250 (1.7)	HC2525	34 (15)	HC2525-0	30 (13)	A	PB14	CP-2
		35 (10.5)		HC2535	36 (16)	HC2535-0				
		50 (15.0)		HE2550	51 (23)	HE2550-0				
3/8 (9)	0.38 NPTF	25 (7.5)	HC3825	36 (16)	HC3825-0	30 (13)				
		35 (10.5)	HD3835	40 (18)	HD3835-0					
		50 (15.0)	HF3850	72 (32)	HF3850-0		60 (27)			
1/2 (13)	0.50 NPTF	25 (7.5)	200 (1.36)	HG5025	70 (31)	HG5025-0	62 (28)	B	PB19	CP-3
		35 (10.5)		HG5035	74 (33)	HG5035-0				
		50 (15.0)		HG5050	79 (36)	HG5050-0				

SERIES "H" REEL AND BASE DIMENSIONS

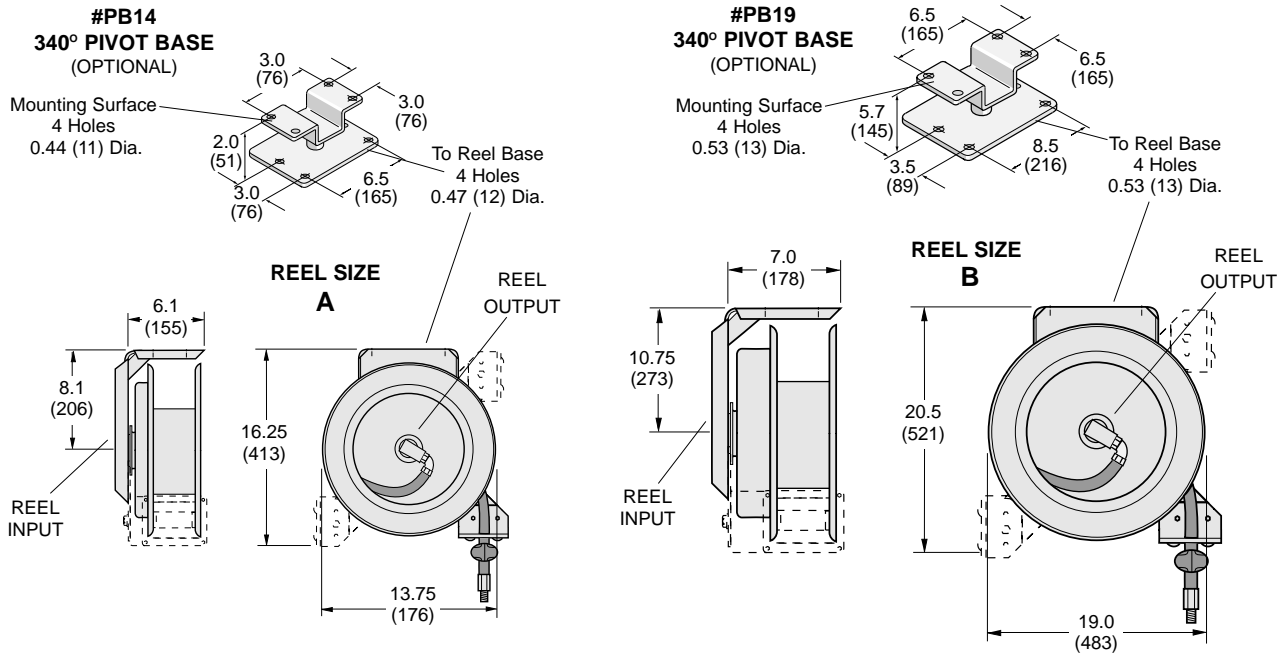

Gleason Reel Corp

P.O. Box 26 • 600 South Clark St.
 Mayville, WI 53050
 Phone: 920-387-4120
 Fax: 920-387-4189