

INSTALLATION and MAINTENANCE INSTRUCTIONS

WIRE ROPE FESTOON KITS with STEEL TROLLEYS

⚠ WARNING

Failure to read, understand, and follow these installation instructions may result in damage to festoon or personal injury.

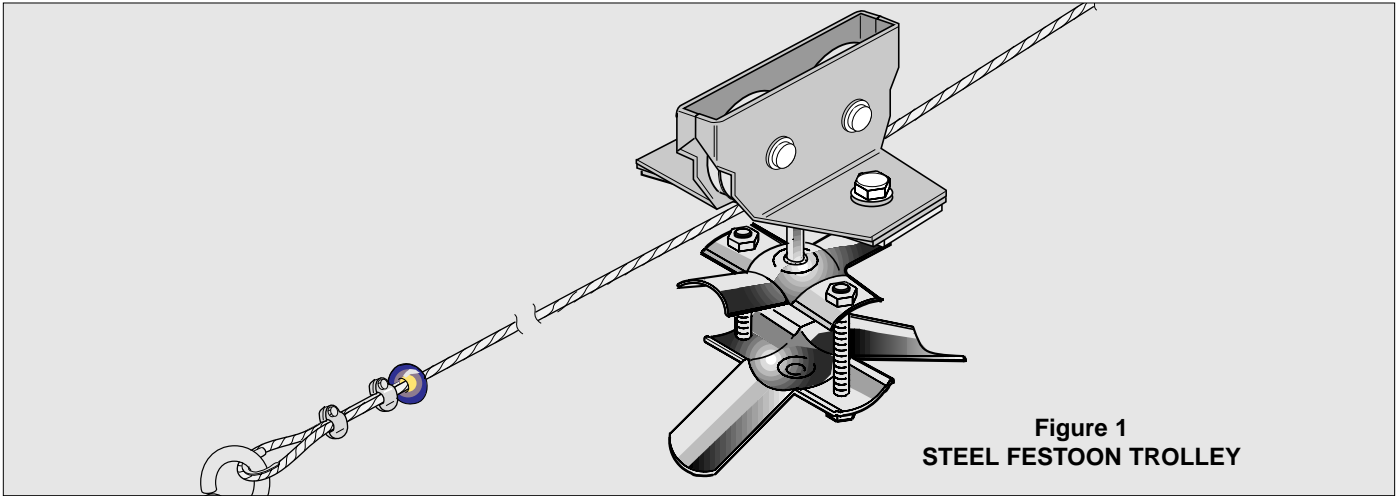

Figure 1
STEEL FESTOON TROLLEY

INSTALLATION

STEP 1– Mount tension brackets or other suitable device for holding stretched wire rope. See Figure 2, right, and Installation Diagrams, following pages.

⚠ WARNING

Wire rope mounts must be able to withstand minimum 1050 lbs.(473kg) lateral force. Improper mounts could give way, causing damage or personal injury.

STEP 2– Install eye-bolt and end clamp to tension bracket on **fixed cable end** of system. See Figure 2. Eye-bolt should protrude maximum 0.25"(6mm) thru nut (Fig. 3).

STEP 3– Cut cable or hose to length shown on tables, following pages. Before cutting, add length needed for end connections.

STEP 4–Refer to Installation Diagrams on following pages. Lay-out trolleys on floor. Install cable or hose in trolley hangers allowing for: 1–Planned loop depth. 2–One additional loop between first intermediate trolley and end clamp. 3–One additional loop between last trolley and tow clamp. 4–Length at each end for hook up. Tighten clamps until just snug.

STEP 5– Thread wire rope through trolleys.

STEP 6–Thread wire rope through eye-bolt on **moving cable end** of system. Install thimble in loop. Secure wire rope with two (2) cable clamps. Do not install rubber bumper. It goes on **fixed cable end** only. Turn one hex nut onto eye-bolt and install flat washer. See Figure 3.

STEP 7– Lift wire rope, including trolleys and cable or hose, into position. Insert eye-bolt on wire rope thru tension bracket on **moving cable end** and secure with flat washer and hex nut.

STEP 8– Slide rubber bumper onto other end of wire rope. Thread wire rope through eye-bolt installed in step 2. Install thimble in loop. Pull wire rope as tight as possible. Secure wire rope with two (2) cable clamps. See Figure 2.

STEP 9– Tighten wire rope by turning nuts on eye-bolts. See Figure 3. Use formula, Figure 4, to determine tension and sag.

STEP 10– Affix cable or hose to end clamp and tow clamp and complete hook-up. Test festoon by moving thru full **Active Travel**. Adjust loop depth as required for best operation. Tighten clamps to secure cable or hose.

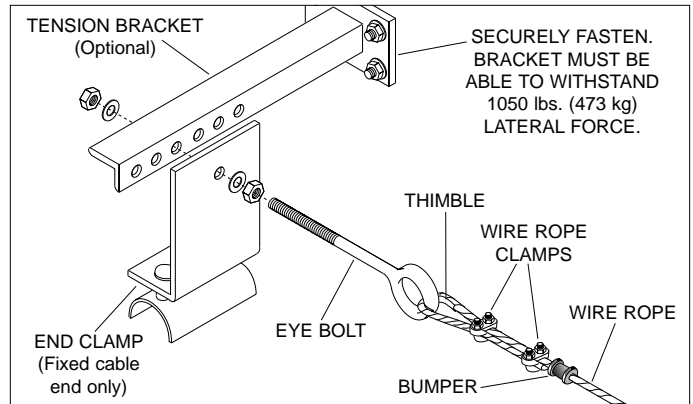

Figure 2

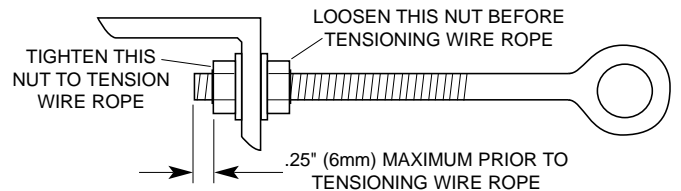

Figure 3

Use this formula to calculate wire rope tension or sag.

$$T = \frac{W \times L}{8 \times S}$$

T= Tension (lbs.) W= Total Weight (lbs.)
L= Length (ft.) S= Sag (ft.)

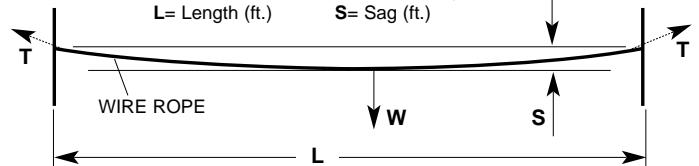
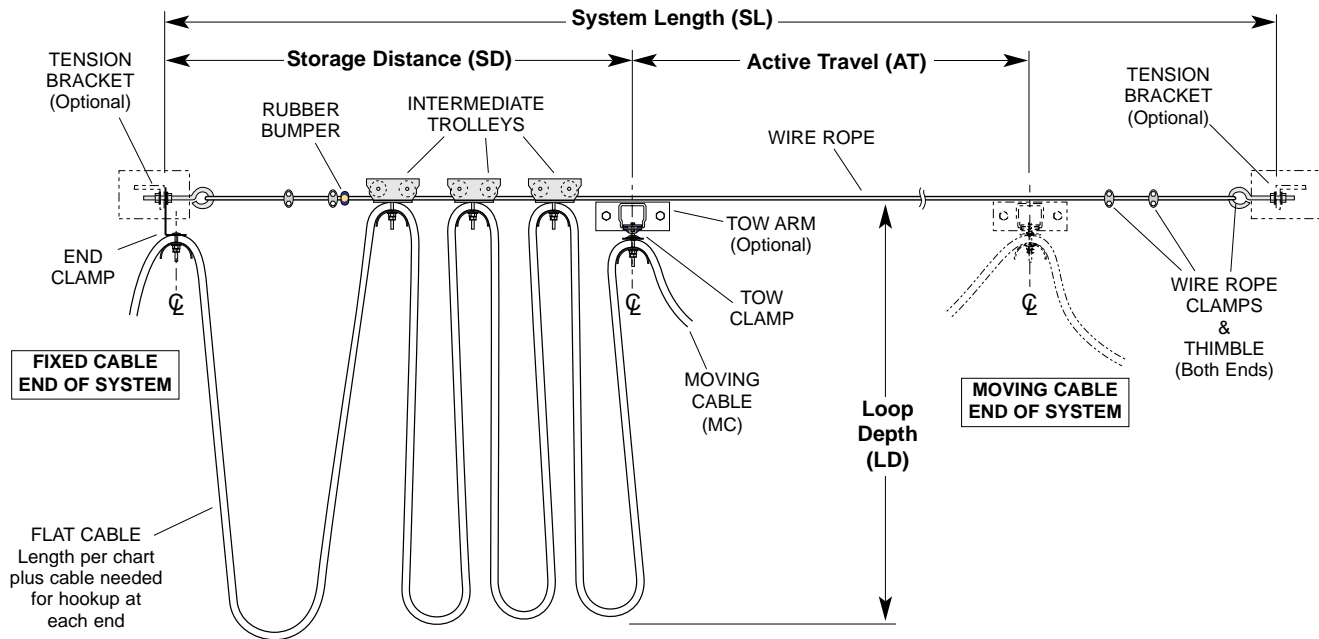

Figure 4

FLAT CABLE FESTOON INSTALLATION DIAGRAM



FLAT CABLE KITS

ACTIVE TRAVEL "AT"	KIT NO.	SYSTEM LENGTH "SL"	STORAGE DISTANCE "SD"	(1) MINIMUM CABLE REQUIRED
LOOP DEPTH For planning purposes.(2) 36"	Maximum cable size: 0.65" x 2.0" (17 x 51mm)	LOOP DEPTH For planning purposes.(2) 36"	MINIMUM. May be greater with stiff cable or short loop.	LOOP DEPTH For planning purposes.(2) 36"
19' 9"	WF-03-36 (3 trolleys)	22' 10"	2' 1"	24'
24' 8"	WF-04-36 (4 trolleys)	28' 0"	2' 4"	29'
29' 8"	WF-05-36 (5 trolleys)	33' 4"	2' 8"	35'
34' 7"	WF-06-36 (6 trolleys)	38' 7"	2' 11"	41'
39' 6"	WF-07-36 (7 trolleys)	43' 9"	3' 3"	47'
44' 6"	WF-08-36 (8 trolleys)	49' 0"	3' 6"	52'
49' 5"	WF-09-36 (8 trolleys)	54' 3"	3' 9"	58'
54' 4"	WF-10-36 (10 trolleys)	59' 6"	4' 1"	64'

(1) KIT NUMBER EXPLANATION

Example: FF08 - 03
Flat cable festoon - Three trolleys

(1) Cable length listed in chart is enough for ACTIVE TRAVEL only, measured centerline to centerline; see diagram above. ADD cable or hose to each end as required for hook-up to your system.

(2) Active travel, system length and minimum cable values on charts are for 36" loop depth only and are provided as guide. Kits include necessary components for festoon system with 36" loop depth at system length shown. Vary loop depth or cable length to suit application. Shorter loop depth = shorter active travel.

Legend

AT = Active Travel SL = System Length
SD = Storage Distance LD = Loop Depth

ROUND CABLE FESTOON INSTALLATION DIAGRAM

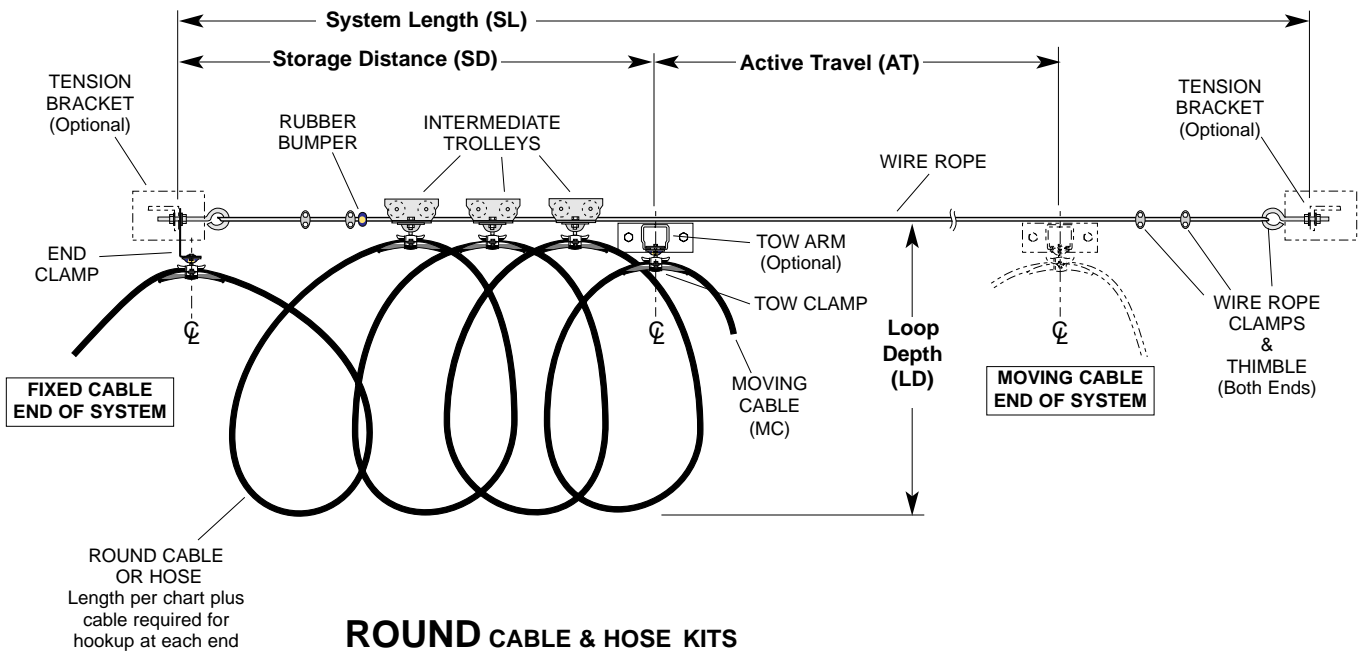

ROUND CABLE & HOSE KITS

ACTIVE TRAVEL "AT"	KIT NO.	SYSTEM LENGTH "SL"	STORAGE DISTANCE "SD"	⁽¹⁾ MINIMUM CABLE/HOSE REQUIRED
LOOP DEPTH <i>For planning purposes.(2)</i> 36"	Refer to note below* for saddle sizes.	LOOP DEPTH <i>For planning purposes.(2)</i> 36"	MINIMUM. May be greater with stiff cable or short loop.	LOOP DEPTH <i>For planning purposes.(2)</i> 36"
17' 9"	WR-03-36	20' 10"	2' 1"	26'
22' 2"	WR-04-36	25' 7"	2' 4"	32'
26' 7"	WR-05-36	30' 3"	2' 8"	38'
31' 1"	WR-06-36	35' 0"	2' 11"	45'
35' 6"	WR-07-36	39' 9"	3' 3"	51'
39' 11"	WR-08-36	44' 6"	3' 6"	57'

KIT NUMBER EXPLANATION

Example: FR04 - 03
 Round cable/hose festoon - Three trolleys
 Size 4 saddle*

(1) Cable/hose length listed in chart is enough for *ACTIVE TRAVEL* only, measured centerline to centerline; see diagram above. **ADD cable or hose to each end as required for hookup to your system.**

(2) Active travel, system length and minimum cable values on charts are for **30" or 48" loop depths only** and are provided as guide. Kits include necessary components for festoon system with 48" loop depth at system length shown. Vary loop depth or cable/hose length to suit application. **Shorter loop depth = shorter active travel.**

*Saddle sizes:

FR04 = 0.30" (7mm) to 0.59" (15mm) OD cable/hose.
 FR05 = 0.60" (15mm) to 0.94" (24mm) OD cable/hose.

PARTS LIST

FLAT CABLE FESTOON COMPONENTS

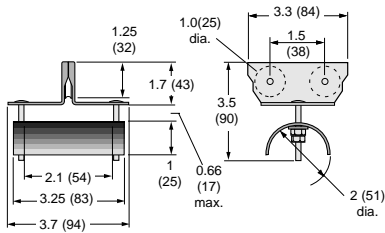

STEEL TROLLEY
#W25-FC-32

Description: Zinc plated steel with dual nylon wheels.
Zinc plated steel cable clamp.

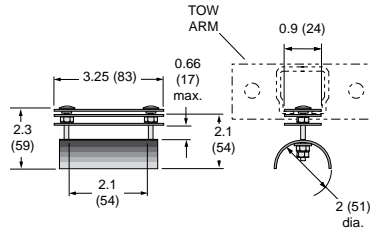

TOW CLAMP
#W25-FE-02

Description: Steel with zinc plating.

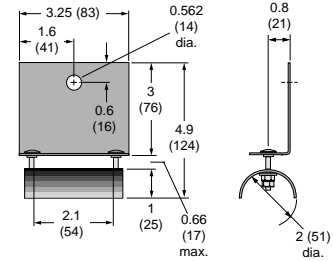

END CLAMP
#W25-FE-02

Description: Steel with zinc plating.

ROUND CABLE & HOSE FESTOON COMPONENTS

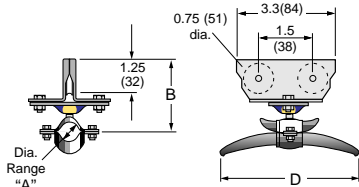

TROLLEY

MODEL NUMBER	*CABLE O.D. "A" in. (mm)	"B" in. (mm)	"D" in. (mm)
W25-RC-11	0.31-0.59 (7-15)	2.75 (70)	2.75 (70)
W25-RC-12	0.60-0.94 (15-24)	2.94 (75)	3.86 (98)
W25-RC-13	0.95-1.25 (24-32)	3.2 (81)	5.0 (127)

Description: Zinc plated steel with dual nylon wheels.
zinc plated steel cable clamp.

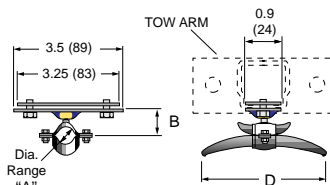

TOW CLAMP

MODEL NUMBER	*CABLE O.D. "A" in. (mm)	"B" in. (mm)	"D" in. (mm)
W25-RT-11	0.31-0.59 (7-15)	1.25 (32)	2.75 (70)
W25-RT-12	0.60-0.94 (15-24)	1.44 (37)	3.86 (98)
W25-RT-13	0.95-1.25 (24-32)	1.7 (43)	5.0 (127)

Description: Steel with zinc plating.

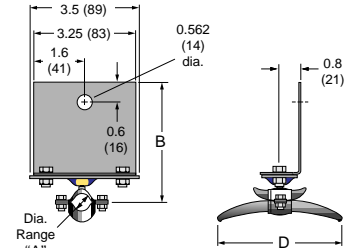

END CLAMP

MODEL NUMBER	*CABLE O.D. "A" in. (mm)	"B" in. (mm)	"D" in. (mm)
W25-RE-11	0.31-0.59 (7-15)	4.06 (103)	2.75 (70)
W25-RE-12	0.60-0.94 (15-24)	4.25 (108)	3.86 (98)
W25-RE-13	0.95-1.25 (24-32)	4.5 (114)	5.0 (127)

Description: Steel with zinc plating.

Tension Bracket #W25-BR-01

Anchor ends of wire rope and fixed end of festoon.

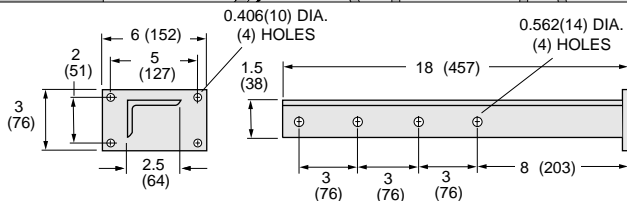
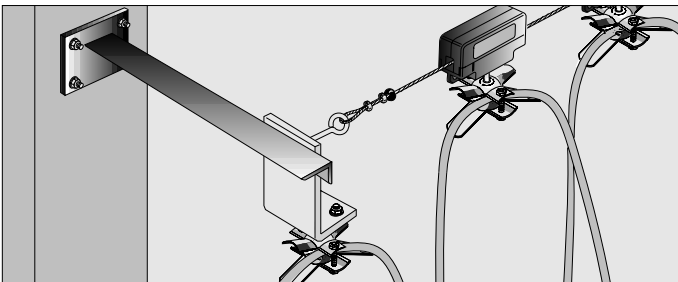

Tow Arm #W25-TA-01

Use on moving end of festoon with Tow Clamp (above).

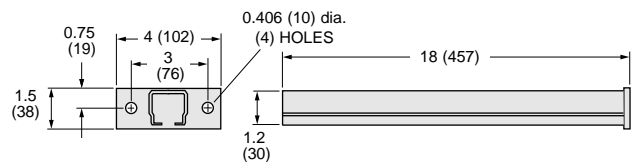
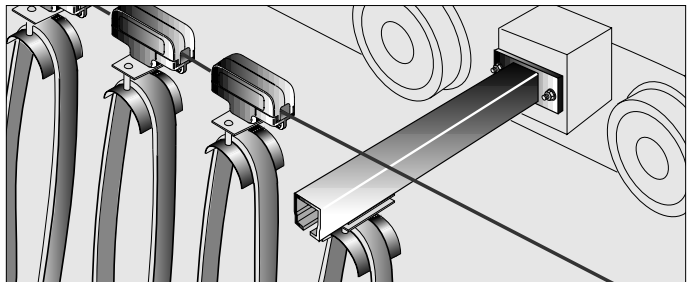

Workplace Solutions

P.O. Box 26
600 South Clark St.
Mayville, WI 53050
Phone: 920-387-5195 • Fax: 1-800-236-7335