

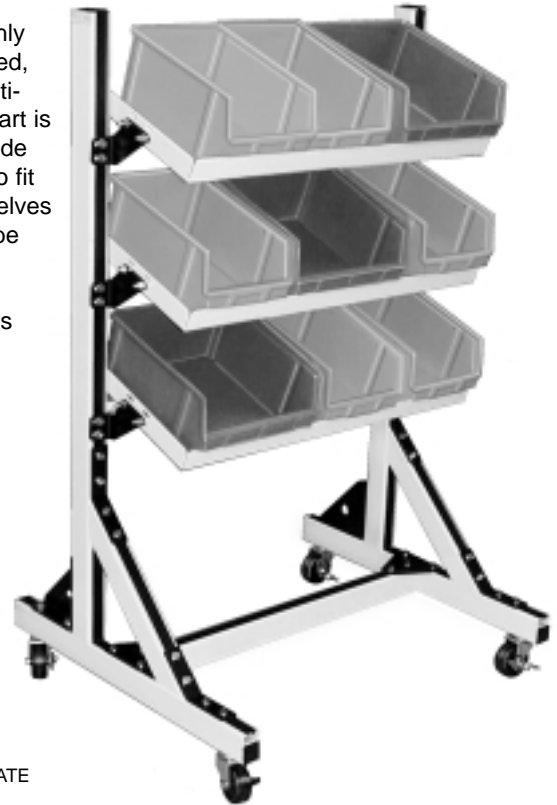
# ASSEMBLY INSTRUCTIONS

## PLACE 'n PICK™ SHELF CART

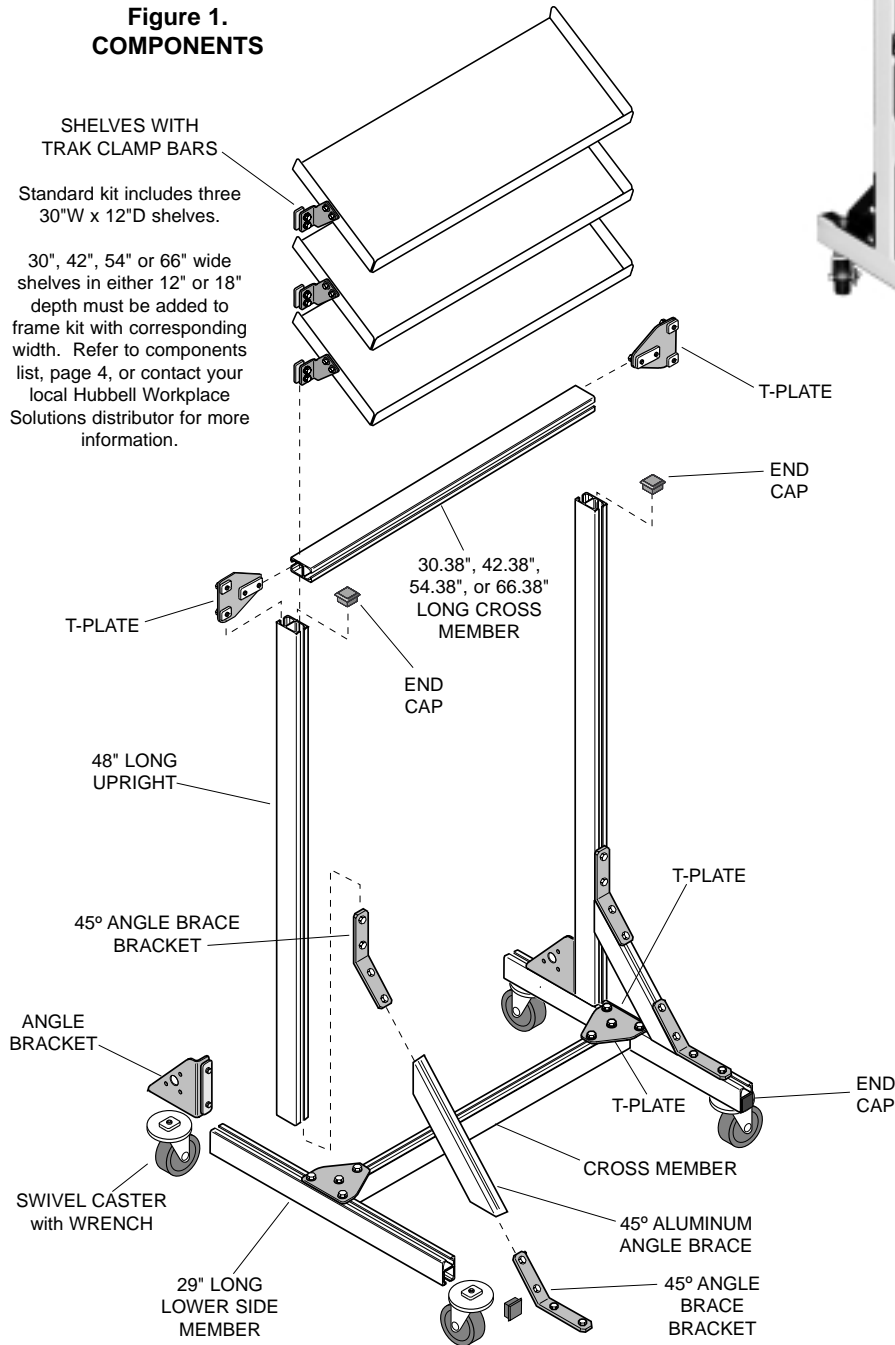
### DESCRIPTION

The **Place 'n Pick™ Shelf Cart Kit System** allows user to assemble a highly versatile mobile shelving unit, equip it with bin boxes (not included) if desired, then roll it where needed in the work area. Shelves may be adjusted for optimum height and angle. **Maximum rated capacity is 100 lbs per shelf.** Cart is available as complete kit, including three 12" deep x 30", 42", 54" or 66" wide shelves (Model numbers HWP-SC30 [42] [54] [66]), or as cart frame only to fit 30", 42", 54" or 66" wide shelves or other accessories such as Bin Bar. Shelves are not included with cart frame kits. Shelves and other accessories must be ordered separately. See listing, page four.

**NOTE:** Prior to assembly, become familiar with the following instructions and names of components as shown below.

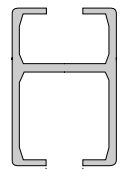


**Figure 1.**  
**COMPONENTS**



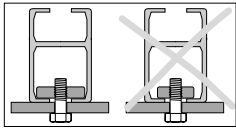
### IMPORTANT ASSEMBLY NOTES

- Components are assembled using the Hubbell Workplace Solutions "ALIGN – SET – TIGHTEN" system; i.e. brackets are clamped to aluminum extrusions with track nuts inside one of the two cavities. Always install single bolt track nuts with widest dimension perpendicular to aluminum rail.
- All main frame members are extruded aluminum rail. Install horizontal members with large cavity down.
- Shelves and all brackets are steel and shipped with assembly hardware (usually track nuts) installed. Some track nuts may have to be reversed (bolt head on opposite side of plate) for proper assembly.

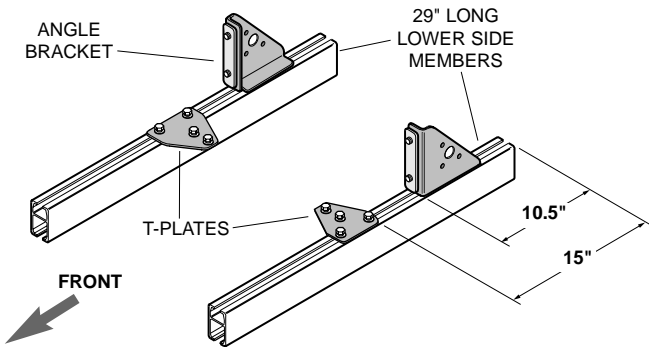


## ASSEMBLY

1. Lay out all components. Locate shelves, casters, and plastic end caps (Fig. 1) and set aside.
2. Locate two angle brackets and two T-plates. Place two 29" aluminum frame members on floor with large slot down. Affix angle brackets and T-plates to side members by sliding track nuts into aluminum rails. Position as shown in Figure 2, and tighten track nuts to secure.



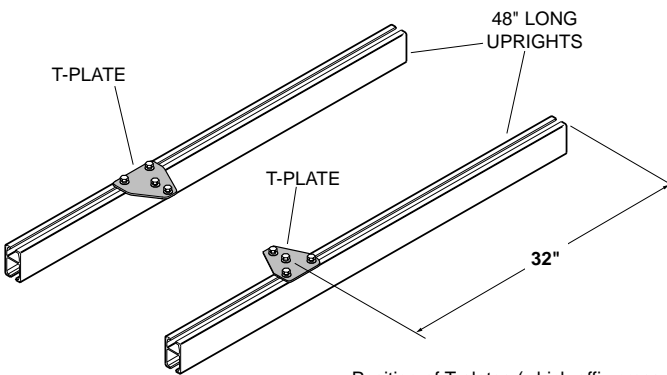
**NOTE:**  
Position short (single bolt) track nuts with long dimension running across opening in aluminum rail.



**Figure 2.**  
**ASSEMBLING LOWER SIDE MEMBERS**

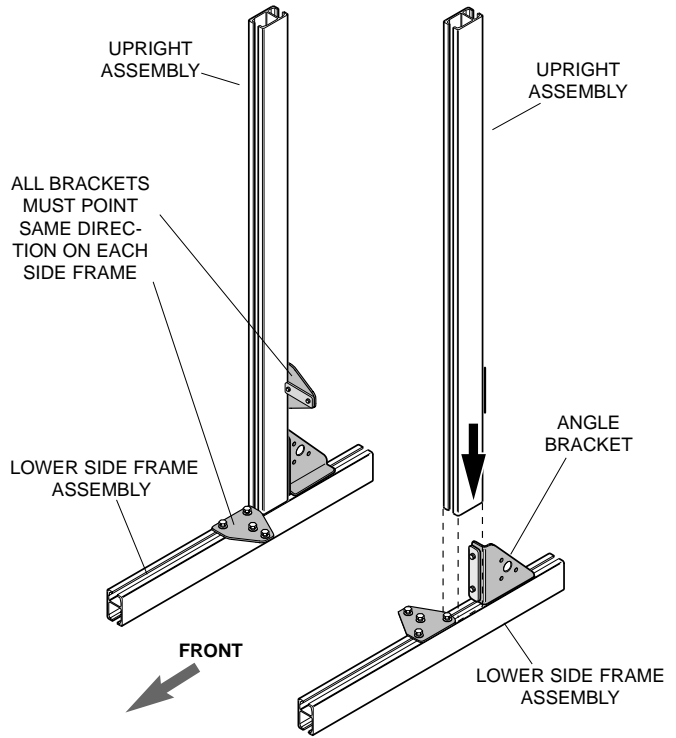
3. Locate two 48" long uprights and two T-plates. Affix T-plates to uprights as shown in Fig. 3. Wrench tighten to secure.

**NOTE:**  
"Right hand" and "Left hand" sub-assemblies are required. Make side frames "mirror images".



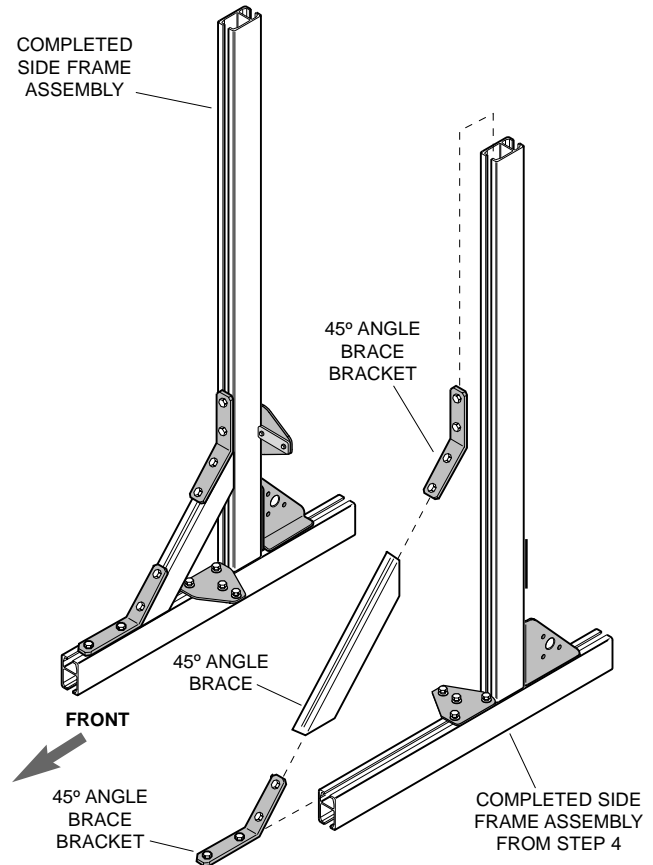
**Figure 3.**  
**ASSEMBLING FRAME UPRIGHTS**

4. Assemble one upright to corresponding lower side frame assembly by sliding onto angle bracket. Tighten. Repeat for other side (Fig. 4).



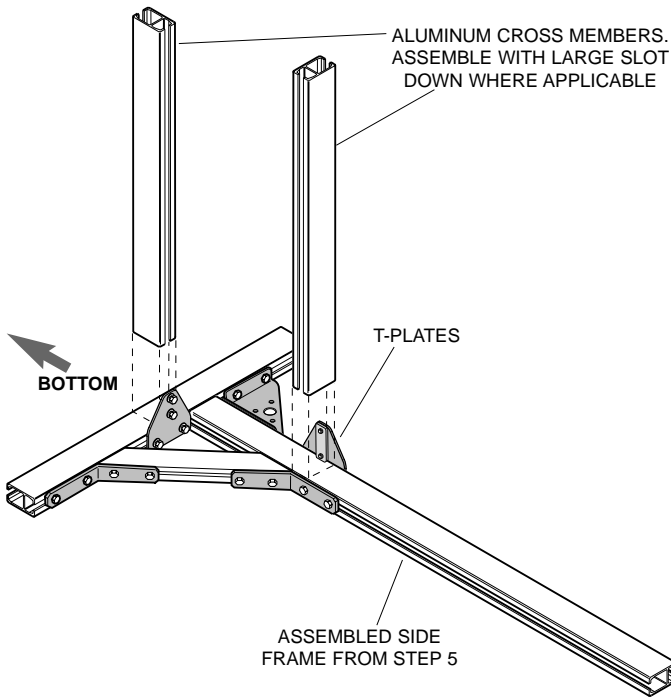
**Figure 4.**  
**ASSEMBLING UPRIGHTS TO LOWER SIDE MEMBERS**

5. Assemble angle braces to frame lower side members and uprights by simultaneously sliding one 45° bracket and angle brace into lower side member and the other 45° bracket down into angle brace and upright. Securely tighten all bolts (Fig. 5).



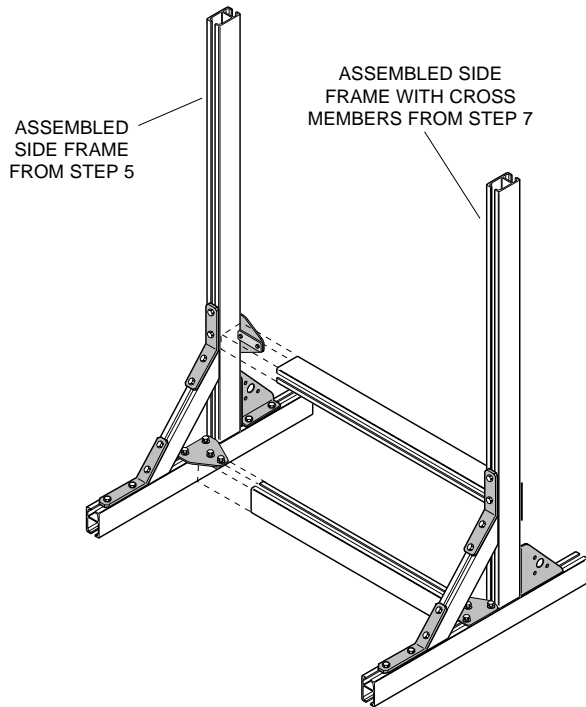
**Figure 5.**  
**INSTALLING ANGLE BRACES**

- Lay one side frame flat and slide two cross members into T-plates. Slide cross members tight against side frame members and securely tighten track nut bolts (Fig 6).



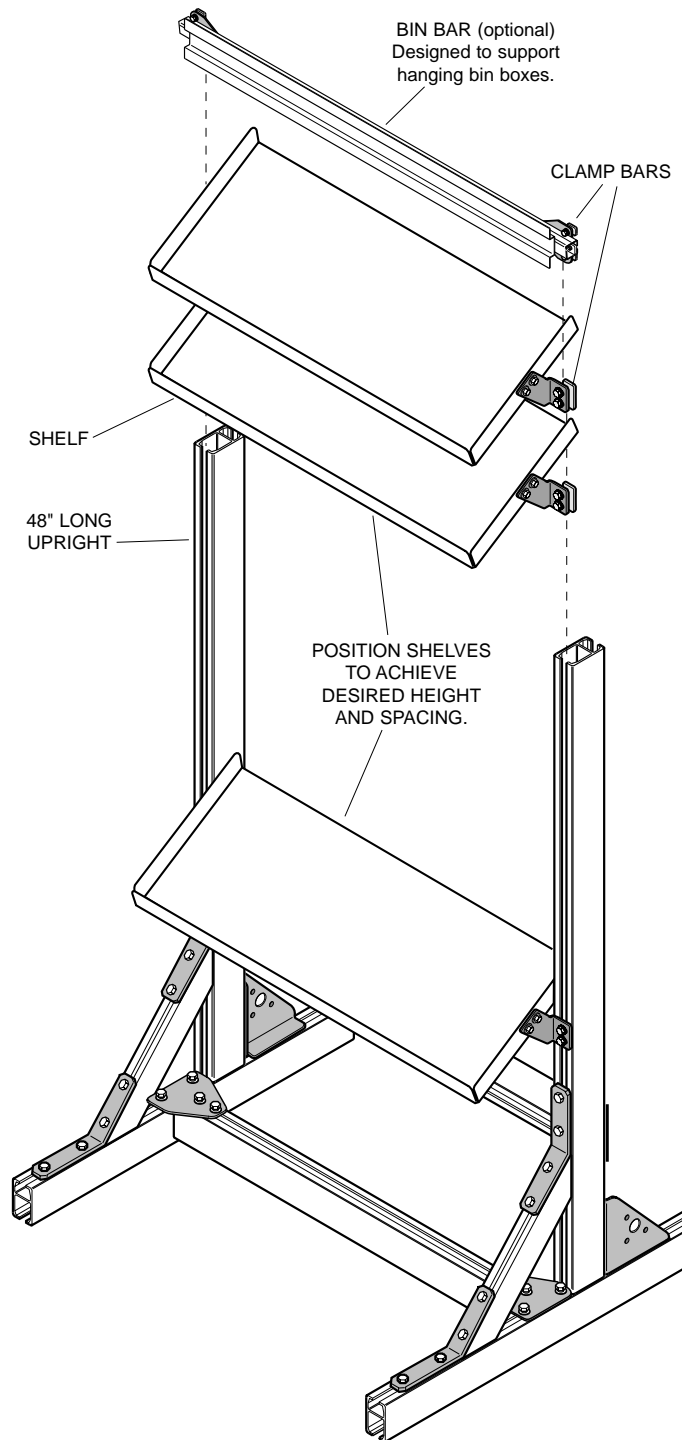
**Figure 6.**  
**INSTALLING CROSS MEMBERS**

- Stand assembly upright and attach other side frame (Fig 7). Square unit and securely tighten all bolts.



**Figure 7.**  
**COMPLETING FRAME**

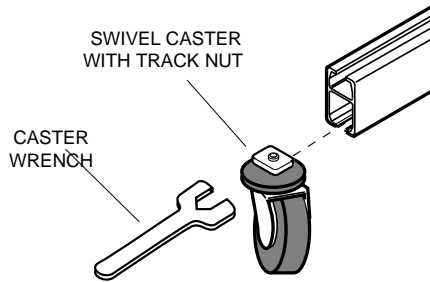
- Loosen clamp bars on shelf and Bin Bar (if used) mounting brackets. Mount shelves and Bin Bar to frame by sliding down from top with clamp bars inside uprights (Fig 8). Refer to additional instructions in Shelf or Bin Bar Kits. Position as desired. Tighten securely.



**Figure 8.**  
**ATTACHING SHELVES**

- Adjust shelves at desired angle(s). Refer to instructions in Shelf Kits for more information.

10. Install casters with wrench included (Fig 9).



**Figure 9  
INSTALLING CASTERS**

11. Install end caps and cover strip (Fig 10).
12. Check to make sure all bolts are tight and that unit is square (all four casters firmly on floor). Adjust as necessary.



**Figure 10.  
COMPLETED UNIT**

**COMPONENT LISTING**

<i>DESCRIPTION</i>	<i>MODEL NO.</i>
Complete Cart Kit-(3) 12"D x 30"W Shelves included . . . . .	HWP-SC30
Complete Cart Kit-(3) 12"D x 42"W Shelves included . . . . .	HWP-SC42
Complete Cart Kit-(3) 12"D x 54"W Shelves included . . . . .	HWP-SC54
Complete Cart Kit-(3) 12"D x 66"W Shelves included . . . . .	HWP-SC66
Frame Kit-For 30" Wide Shelves (Shelves NOT included) . . . . .	HWP-SC03
Frame Kit-For 42" Wide Shelves (Shelves NOT included) . . . . .	HWP-SC04
Frame Kit-For 54" Wide Shelves (Shelves NOT included) . . . . .	HWP-SC05
Frame Kit-For 66" Wide Shelves (Shelves NOT included) . . . . .	HWP-SC06
Shelf-12"D x 30"W . . . . .	WS50-SS03
Shelf-12"D x 42"W . . . . .	WS50-SS04
Shelf-12"D x 54"W . . . . .	WS50-SS05
Shelf-12"D x 66"W . . . . .	WS50-SS06
Shelf-18"D x 30"W . . . . .	WS50-SS183
Shelf-18"D x 42"W . . . . .	WS50-SS184
Shelf-18"D x 54"W . . . . .	WS50-SS185
Shelf-18"D x 66"W . . . . .	WS50-SS186
Bin Bar-36" (Fits 30"W Frame Kit) . . . . .	WS50-BB03A
Bin Bar-48" (Fits 42"W Frame Kit) . . . . .	WS50-BB04A
Bin Bar-60" (Fits 54"W Frame Kit) . . . . .	WS50-BB05A
Bin Bar-72" (Fits 66"W Frame Kit) . . . . .	WS50-BB06A
Cover Strip-20' long roll. Cut to length. . . . .	WA-CS20



**Workplace Solutions**

P.O. Box 26 • 600 South Clark St.  
Mayville, WI 53050  
Phone 920-387-5195