

## “Z” BRACKET INSTALLATION

Supplement to Light Installation Instructions.

Optional “Z” brackets allow light to be mounted with bottom of light fixture is flush with bottom of horizontal workstation support rail.

**NOTE:** “Z” brackets are designed to be used for light support rails only and are **not recommended for supporting tool rails.**

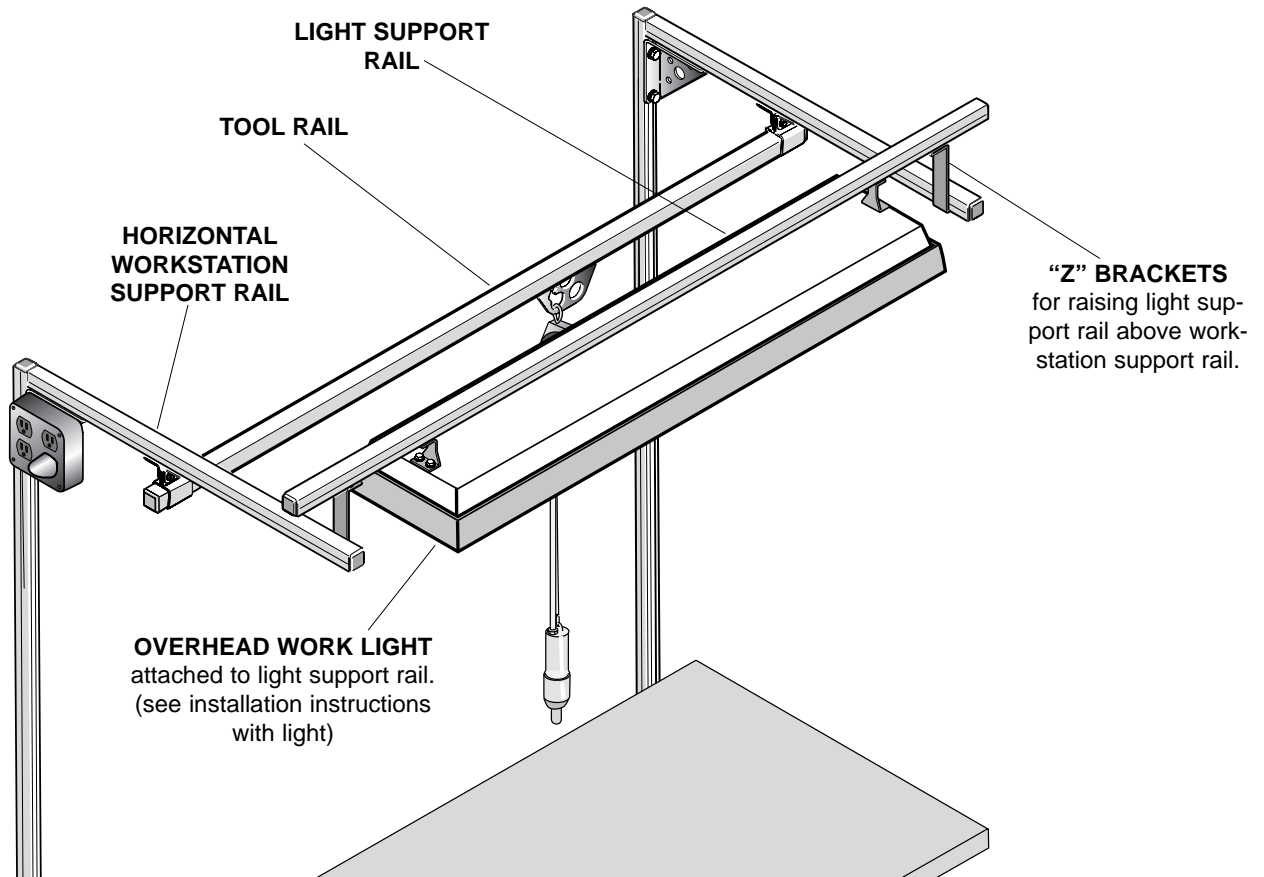

Figure 1-Reference Drawing

### “Z” BRACKET INSTALLATION

1. Remove End Caps, which would interfere with insertion of track nuts, from horizontal workstation support rails and light support rail.
2. Install light, centering it on light support rail (Fig. 1) as shown in separate instructions provided with light.
3. Loosen track nuts on “Z” brackets and slide into ends of light support rail (Fig. 1). Finger tighten only.
4. Slide track nuts on bottoms of “Z” brackets into ends of horizontal workstation support rails.
5. Position light where desired.
6. Tighten all track nuts, clamping light support rail to workstation support rails.
7. Complete light installation.

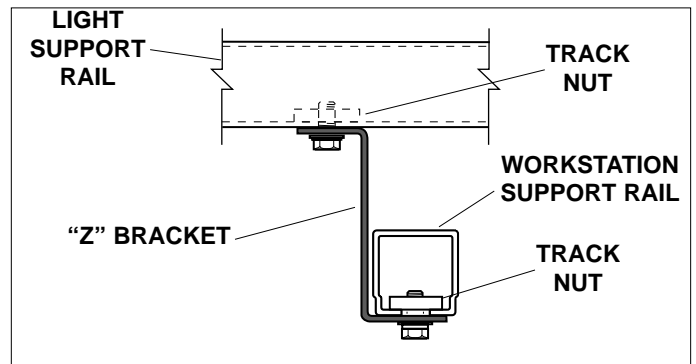

Figure 2-END VIEW



**Workplace Solutions**

P.O. Box 26  
600 South Clark St.  
Mayville, WI 53050  
Phone: 920-387-5195